



RockSizer

Jaw Crushers



Quality Engineered
Excellence Since 1911

Parker Jaw Crusher 'RockSizer' Series

Parker Plant Limited have been engineering rock crushers since 1911 and today thousands of jaw crushing units have been installed around the world. Jaw crushers are intended for primary crushing applications and are ideal for use within quarries & recycling/demolition Industries. 'RockSizer' Single toggle up-thrust type range of crushing units are designed to crush the toughest materials in some of the most difficult conditions known, each machine has been designed to produce maximum reduction of material, whilst providing a stable and reliable machine that will benefit the customer. Each and every machine is built by hand and incorporates a proven all-welded steel body.

Advantages:

- Increased production compared with other designs
- Less manganese wear per ton crushed
- Improved product shape
- More efficient utilisation of power
- Grease filled labyrinth seals to prevent ingress of dust
- Reversible jaw plates to maximise jaw plate life

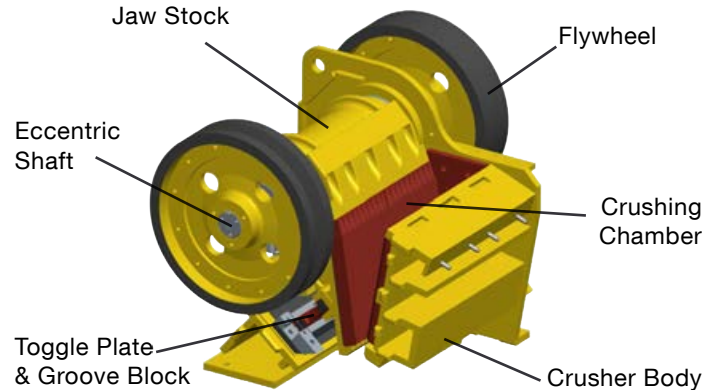

All-Steel Fabricated Body

This is a fully stress relieved all welded steel fabrication with single steel plate walls and strong side stiffening webs. The body is electrically welded to provide exceptional strength through-out including the side bearing housing. The bearing top-caps are easily removed to enable the jaw stock and shaft assembly to be lifted out complete.

Eccentric Shaft

A high quality nickle-chrome forged steel shaft, fully machined to the highest accuracy and heat treated to obtain the finest possible finish and ensure longer bearing life. By such meticulous care in production, outstanding service is obtained from 'RockSledger' crushers over long periods of time.

Jaw Stock & Body Bearings

Every jaw crusher is fitted with self aligning spherical roller bearings. Their higher shock-load bearing capacity and effective labyrinth seals protect from the ingress of dirt and dust. The body bearings are grease lubricated and fitted with valves to prevent over-greasing.

Jaw Stock

Strongly constructed from cast steel with deep webbing to give strength with reasonable lightness. The face which receives the swing jaw and the groove which receives the toggle plate are both machined in-house to ensure an accurate fit and good alignment.

Toggle Plate & Groove Block

The toggle plate is a high quality iron casting with the ends machined to a segment of a circle to minimise rubbing and reduce wear.

Crushing Chamber

Both fixed and swing jaws are corrugated high quality manganese steel castings with equal cross sections along the length of the jaw which are reversible, top to bottom. Both Jaws are fixed into the chamber by wedge locking system. The main frame incorporates side wear resistant liners and the design of the jaw liners protect the inlet and outlet points.

Changing Jaw Settings

Adjustment to the jaw setting is carried out by adding or removing shim plates of varying thicknesses behind the groove block, which is adjusted by a hydraulic ram with hand operated pump.

Kinematics

Interchangeable large diameter flywheels, one grooved for vee belt drive are fitted. The fly wheels are specifically designed to provide the right amount of inertia resulting in a higher through put capacity.

Size of Crusher	Max Cube Feed Size	Approximate Weight	No. & size of Vee Belt	Power to Drive	Jaw Setting: (mm)								
					(mm)	(kg)	(kW)	30	40	50	65	75	100
600 x 300	280	4,200	4 SPC	30	25-35	30-45	35-55	40-65	45-75				
700 x 450	410	6,700	5 SPC	37		35-45	46-60	50-65	65-85	80-105	100-130		
800 x 480	435	10,260	4 SPC	55		38-49	50-65	60-80	75-100	90-120	105-140		
800 x 500	455	10,260	4 SPC	55			50-65	60-80	75-100	90-120	105-140		
950 x 300	280	6,685	4 SPC	45	40-55	50-65	60-80	70-90	80-105				
1000 x 600	575	16,600	8 SPC	110				85-105	100-135	125-160	140-190	165-210	
1000 x 625	600	16,600	8 SPC	110					100-135	125-160	140-190	165-210	
1200 x 300	280	11,175	5 SPC	90	55-75	65-90	80-105	95-125	105-135				

NOTE: Capacities quoted are intended as a guideline only, and are based on a clean, dry graded continuous feed material (weighing 1600kg/m³ (100lb/ft³) and a S.G of 2.7 average), which will readily enter the crusher feed opening without obstruction, with 100% greater than the jaw setting and 25% less than twice the jaw setting. Actual capacities can vary considerably from those given, due to the following application and operational factors: 1) **MATERIAL** - Friability & Toughness, 2) **FEED CONDITIONS** - Grading of feed size (Compliance with Euro STD), 3) **INSTALLATION** - Method of feeding, Removal of under size. [Operation at settings outside those stated should be referred to the works].

Parker Plant Limited, Viaduct Works, Canon Street, Leicester, LE4 6GH, United Kingdom

T: +44 (0) 116 266 5999 F: +44 (0) 116 266 4422 W: www.parkerplant.com E: sales@parkerplant.com

All reasonable steps have been taken to ensure the accuracy of this publication. However, due to our policy of continual product development, Parker Plant Limited reserve the right to change details without prior notice. All machines supplied in accordance with our standard conditions. Illustrations and photos may show optional equipment.