







# FOUNDATION PLANS

## MANSFIELD No 3

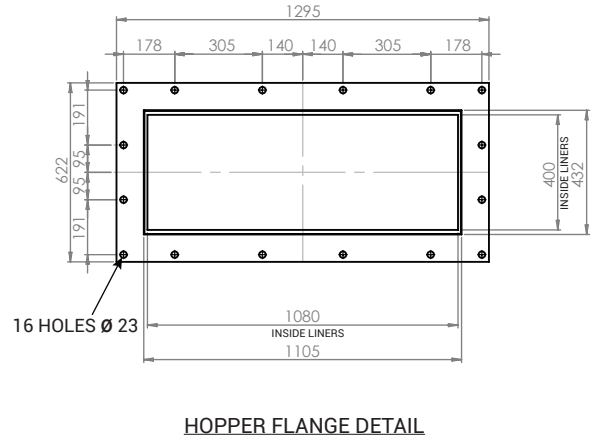
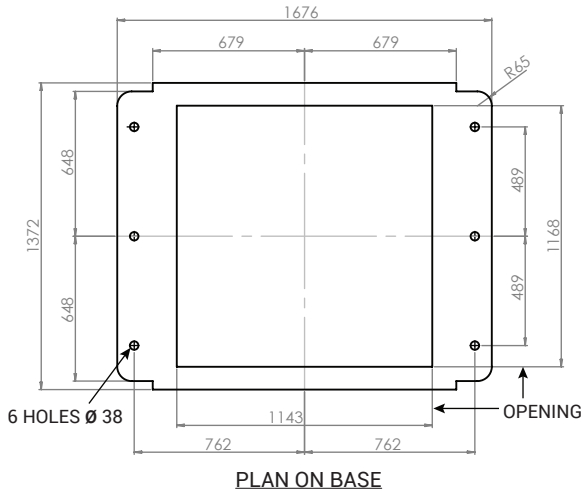

## MANSFIELD No 4

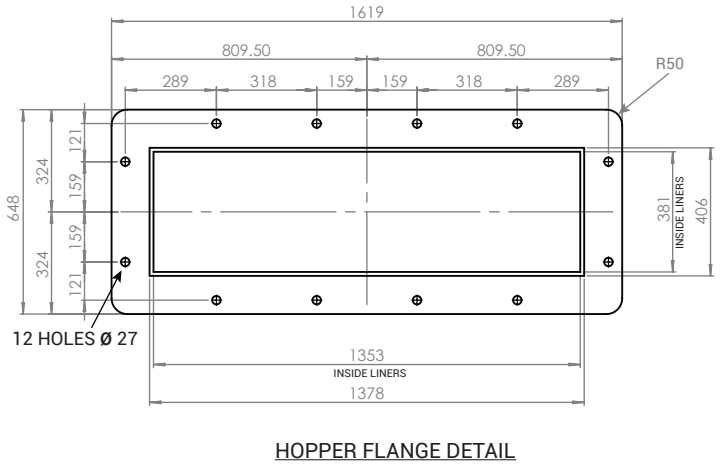
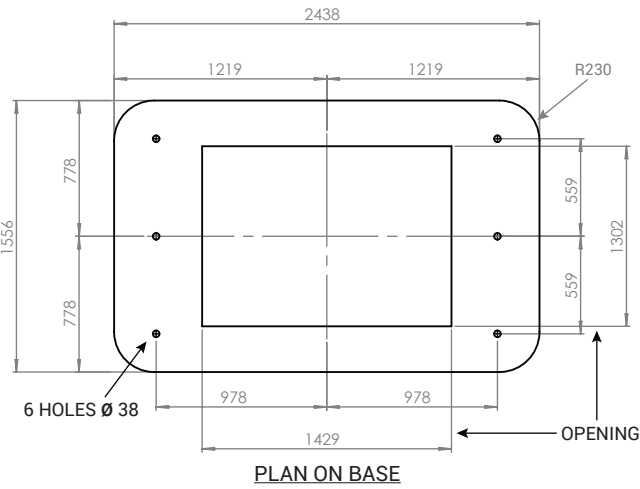

## MANSFIELD No 5

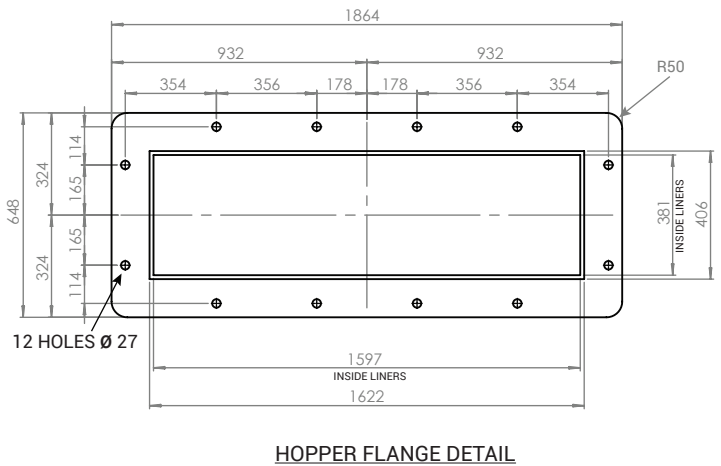
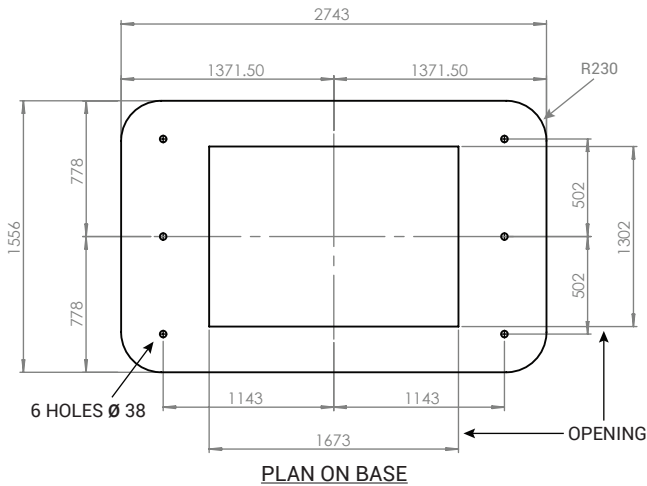

THIS BROCHURE IS TO ASSIST YOU IN SELECTING A MANSFIELD CRUSHER FOR YOUR PROJECT AND WE WOULD WELCOME THE OPPURTUNITY TO DISCUSS YOUR INDIVIDUAL REQUIREMENTS.

OUR POLICY IS ONE OF CONTINUAL DEVELOPMENT. ALL INFORMATION CONTAINED WITHIN THIS BROCHURE IS SUBJECT TO CONFIRMATION AND WE RESERVE THE RIGHT TO AMEND SPECIFICATIONS OR ANY INFORMATION WITHOUT PRIOR NOTICE.

## MANSFIELD CRUSHERS LTD

UNIT 24, CASTLE PARK INDUSTRIAL ESTATE  
FLINT, FLINTSHIRE, CH6 5XA, UNITED KINGDOM

TEL: +44 (0) 1352 732284

EMAIL: SALES@MANSFIELDCRUSHERS.CO.UK

WEB: WWW.MANSFIELDCRUSHERS.CO.UK