

# 775E

## Off-Highway Truck



### Engine

Engine Model	Cat <sup>®</sup> 3412E	
Gross Power	567 kW	760 hp
Flywheel Power	544 kW	730 hp

### Weights

Gross Machine Weight	108 400 kg	239,000 lb
----------------------	------------	------------

### Operating Specifications

SAE (2:1) Capacity	41.2 m <sup>3</sup>	53.9 yd <sup>3</sup>
Nominal Payload	63.5 tonnes	70 tons



# 775E Off-Highway Truck

*Engineered for performance, designed for comfort, built to last.*

---

## Power Train - Engine

The power train features the 3412E diesel engine and Hydraulic Electronic Unit Injector (HEUI™) for efficient operation. **pg. 4**

---

## Power Train - Transmission

The Cat seven-speed, power shift transmission, matched with the direct-injection 3412E diesel engine provide constant power over a wide range of operating speeds. **pg. 5**

---

## Engine/Power Train Integration

The Caterpillar® Data Link System electronically combines engine, transmission, brake and operational information to optimize overall truck performance. The Electronic Technician (ET) accesses stored diagnostic data, significantly reducing downtime. **pg. 6**

---

## Truck Body Options

- ✓ The 775E offers flat floor quarry, flat floor lined and dual-slope body options to meet specific user applications. A full offering of attachments and customized options are available to meet specific needs. **pg. 11**

---

## Operator Station

Controls and gauges are positioned to maximize productivity and comfort. The cab includes an air suspension seat and advanced electronic monitoring system. Adjustable telescoping steering column, electric wipers, window and body controls reduce operator effort and simplify control. **pg. 12**

### ***Top Performance.***

*The 775E is designed for high production and low cost-per-ton hauling in various applications.*

### ***Reliable, durable operation.***

*Rugged construction and easy maintenance can help extend life with low operating costs.*



---

### **Oil Cooled, Rear Disc Brakes**

Caterpillar oil-cooled, multiple disc brakes offer exceptional, fade-resistant braking and retarding. **pg. 8**

---

### **Integrated Braking Control (IBC)**

IBC integrates the optional Automatic Retarder Control and Traction Control System (TCS) into one system to enhance truck performance and productivity and improve operator confidence. **pg. 9**

---

### **Structures**

Caterpillar truck frames are built for severe applications. Mild steel provides flexibility, durability and resistance to impact loads. Castings and forgings in high stress areas of the frame provide great structural strength. **pg. 10**

---

### **Serviceability/Total Customer Support**

- ✓ Easy serviceability access, QuickEvac™ system, on- and off-board diagnostics, machine management service, worldwide parts availability and literature support represents the Caterpillar commitment to customer support. **pg. 14**

---

### **Systems/Applications**

Numerous options and a system approach to match the 775E to the most appropriate loader meets customer needs for various applications. **pg. 16**



✓ *New Feature*

## Power Train - Engine

*The twelve-cylinder, turbocharged engine is built for power, reliability, economy and with the HEUI™ fuel system, meets worldwide emissions.*

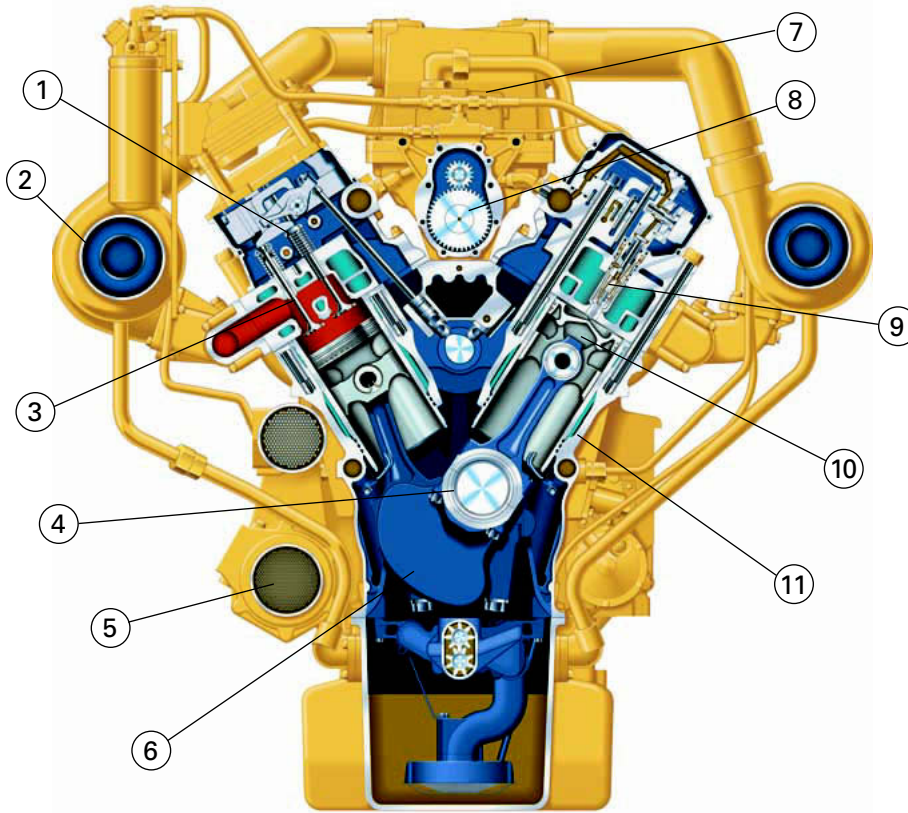

**Cat 3412E Diesel Engine.** The four-stroke design uses long power strokes for more complete fuel combustion and optimum efficiency. High displacement and a low speed rating can help extend engine life.

**Torque Rise.** The 33 percent torque rise provides high lugging force during acceleration and less down-shifting on grade or in rough underfoot conditions. The torque rise effectively matches the transmission shift points to provide maximum efficiency and faster cycle times.

### Engine.

- 1) Valve Rotators
- 2) Turbocharger
- 3) Stellite-Faced Valves
- 4) Steel-Backed, Copper-Bonded Bearings
- 5) Oil Cooler

- 6) Forged Crankshaft
- 7) Aftercooler
- 8) Adjustment-Free, Fuel Injection Pumps
- 9) Hydraulic Injectors
- 10) Forged Steel Pistons
- 11) Full-Length, Water-Cooled Cylinder Liners

**Engine Features.** Contributing to the 3412E power and reliability are:

- High pressure injection
- Full electronic control
- One piece forged steel pistons with three rings cooled by oil spray
- Copper-bonded crankshaft bearings
- Hardened crankshaft journals
- Dry-type, radial seal air cleaners with primary and secondary elements and precleaner

- Direct-electric, 24-volt starting system with 50-amp alternator and two 172-amp-hour, low maintenance, high output, 12-volt batteries

### Hydraulic Electronic Unit Injector (HEUI™).

The HEUI system is a proven high-pressure, direct injection fuel system. This system electronically monitors operator and machine inputs to optimize engine performance. The HEUI system is unique in its ability to independently control injection pressure over the entire engine operating range. This allows complete control over injection timing, duration, performance and efficiency. Rate shaping technology modifies the heat release characteristics of the combustion process for significant decreases in sound and emission levels. Exhaust smoke is significantly reduced through precise, electronic control of fueling limits and injection timing of the HEUI.



### Electronic Control Module (ECM).

The ECM monitors key functions and logs critical indicators. The Electronic Technician can access this diagnostic information for easier maintenance and repair.



## Power Train - Transmission

The Cat seven-speed, power shift transmission gets the job done smoothly and quickly.

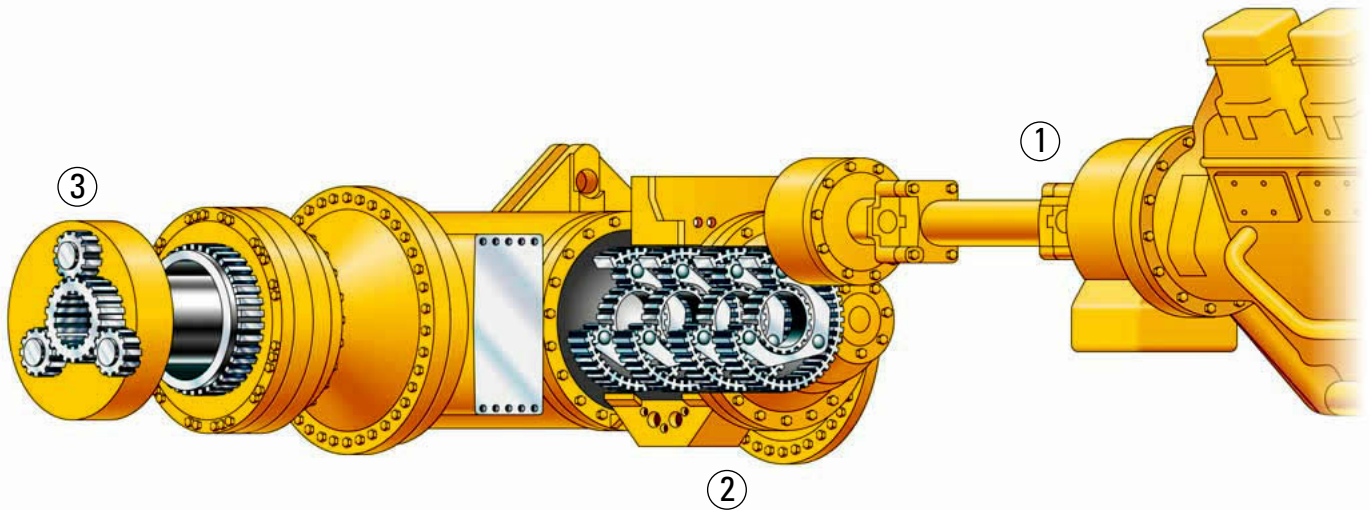

**Transmission.** The Cat seven-speed, power shift transmission, matched with the direct-injection 3412E diesel engine provide constant power over a wide range of operating speeds.

**Transmission Features.** Include:

- Seven speeds forward, one reverse
- Torque converter driven in reverse
- First gear has both torque converter drive and direct drive
- Second through seventh gears are direct drive
- Single-lever shift control provides automatic shifting in all gears up to the one selected by the control lever
- Each shift is individually modulated for maximum smoothness
- Separate hydraulic circuit with cooler
- Electronic control has built-in diagnostics and fault memory, event memory and programmable features
- Control throttle shifting
- Economy shift mode

**1) Lock-up Torque Converter.** Combines the maximum rimpull and cushioned shifting of torque converter drive with the efficiency and performance of direct drive.

- Engages at approximately 6.9 km/h (4.3 mph), delivering more power to the wheels
- Lock-up clutch quickly releases and re-engages during shifts, maintaining power wind-up, improving transmission life and increasing operator comfort

**2) Planetary Power Shift Transmission.** Utilizes a modulating pressure valve to regulate clutch pressure rise and fall to ease clutch engagement. This reduces shock loads on power train components. Features include:

- Large diameter clutches and robust planetary gears and bearings
- Rotating clutch pressure seals minimize drag losses and improve reliability
- 35 percent gear splits between all gears match Cat engine design for optimum use of engine power with minimized shifting and torque converter use

**3) Final Drive.** Final drive and differential torque multiplication of 17.48:1 further reduces stress on the drive train.

**Axles.** Full floating axles are shot-peened to relieve internal stresses and increase durability. Rolled splines also provide increased service life.

**Wheel and Rims.** Cast rear wheels and Cat center-mount rims are mounted using studs and nuts to minimize maintenance and maximize durability.

**Transmission Chassis Controller (TCC).** TCC uses electronically transferred engine rpm data to execute shifts at preset points for optimum performance and efficiency. This integration allows:

- Programmable top gear limit
- Control throttle shifting
- Directional shift management
- Neutral coast inhibitor
- Economy shift mode

**Integration.** The Caterpillar power train integration provides increased component life and operator comfort.

## Engine/Power Train Integration

Combining the electronic Engine Control Module (ECM) with the Caterpillar Transmission Chassis Controller (TCC) allows critical power train components to work more intelligently.

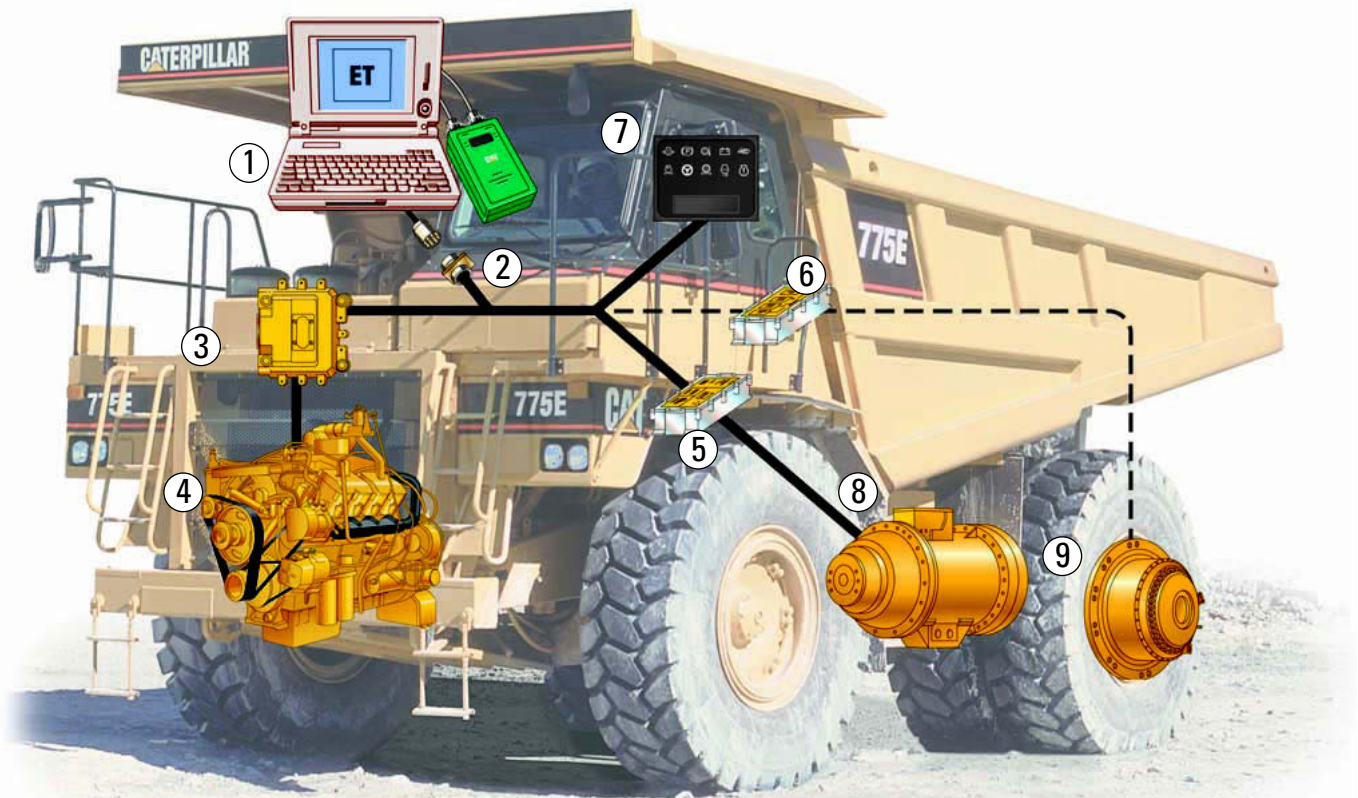

### Integration.

- 1) Electronic Technician
- 2) Cat Data Link System
- 3) Engine Control Module
- 4) Engine
- 5) Transmission Chassis Controller
- 6) Automatic Retarder Control, Traction Control System and Integrated Brake Controller
- 7) Caterpillar Electronic Monitoring System
- 8) Transmission
- 9) Oil-cooled Brakes

**Cat Data Link.** The Cat Data Link electronically integrates the machine's computer systems, which allows communications and provides the following benefits:

- **Controlled Throttle Shifting.** Engine rpm is regulated during a shift to reduce driveline stress for smoother shifts and longer component life.
- **Economy Shift Mode.** Modifies engine maps, resulting in improved fuel consumption.

**Directional Shift Management.** Regulates engine speed during directional shifts to prevent damage caused by high speed directional changes.

### Elevated Idle Neutral Coast Inhibitor.

Helps prevent the transmission from shifting to neutral at speeds above 6.5 km/h (4 mph).

**Body-up Shift Inhibitor.** Helps prevent the transmission from shifting above a pre-programmed gear without the body fully lowered.

**Event Memory.** Records machine management data that can be accessed using the Electronic Technician. Recorded information includes:

- Shift histograms
- Operator-induced events
- Lock-up clutch counter
- Machine overspeed
- Transmission overspeed

**Electronic Technician (ET).** The electronic engine and transmission controls provide exhaustive diagnostic capability for service technicians. The ability to store both active and intermittent indicators will simplify problem diagnosis and reduce total repair time, resulting in improved mechanical availability and lower operating cost.

- ET accesses data stored in the engine and transmission controls via the Cat Data Link System.
- ET displays the status of all engine parameters including throttle position, timing and fuel flow.

- ET replaces 13 mechanical tools to perform functions like cylinder cutout checks, injector solenoid tests and timing calibration.

**Caterpillar Electronic Monitoring System (CEMS).** CEMS allows the operator to view requested information and utilizes a three-category warning system to alert the operator to abnormal machine conditions.

**Optional Attachments.** Caterpillar offers optional attachments that integrate with the Cat Data Link System.

• **Automatic Retarder Control (ARC).** Works with other electronic components to automatically control retarding on grade, maintaining approximately 2,230 rpm.

• **Traction Control System (TCS).** Improves performance in poor underfoot conditions by electronically monitoring and controlling wheel slippage.

• **Integrated Brake Controller (IBC).** Combines ARC and TCS, reducing the number of electronic components and electrical lines.

## Oil Cooled, Rear Disc Brakes

*Rear braking lets the operator concentrate on the haul road.*

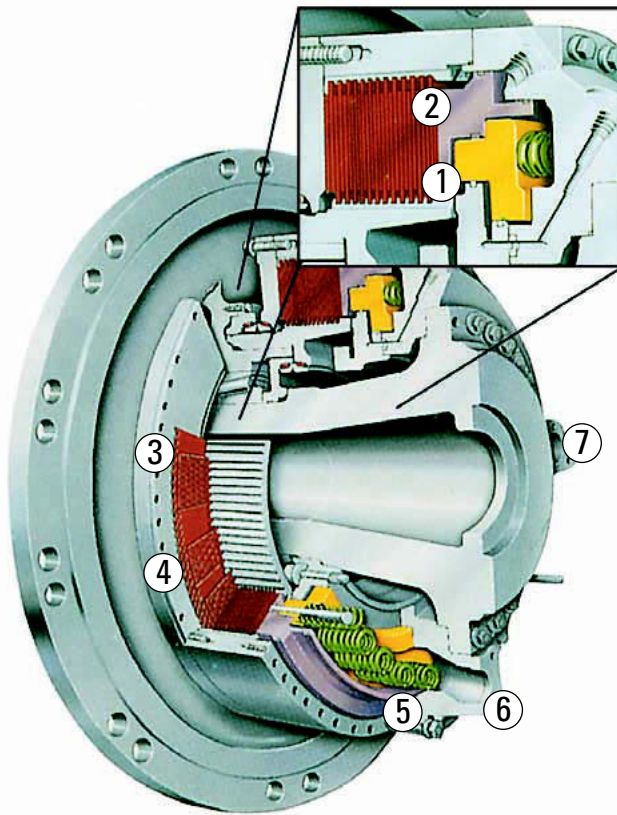

### Brakes.

- 1) Parking/Secondary Piston
- 2) Service/Retarding Piston
- 3) Friction Discs
- 4) Steel Plates
- 5) Actuating Springs
- 6) Cooling Oil In
- 7) Cooling Oil Out

**Multiple Disc Brakes.** Caterpillar forced oil-cooled, multiple disc brakes are continuously cooled for exceptional, fade-resistant braking and retarding. The optional ARC and TCS utilize the oil-cooled rear brakes to enhance truck performance and increase productivity.

**Oil-Cooled Disc Brakes.** Are designed and built for reliable, adjustment-free operation providing superior performance and service life in comparison to shoe-type and dry-disc systems.

**Oil Film.** An oil film prevents direct contact between the discs. Absorbing the braking forces by shearing oil and carrying heat away, this design extends brake life.

**Secondary Braking.** Spring-applied, hydraulically released, oil-cooled disc brakes are located on the rear axle. The front brakes will activate as part of the secondary system, even if switched out of service.

**Parking Brakes.** Spring-applied, hydraulically released parking brakes use wet disc brakes in the service system. A toggle switch activates the parking brake.

**Pistons.** A Caterpillar two-piston design combines the service, secondary and parking brakes, along with retarding functions. The primary piston hydraulically actuates both service and retarding functions. The secondary piston is spring-applied and held in the disengaged position by hydraulic pressure. If hydraulic system pressure drops below a certain level, the spring-applied secondary piston automatically applies the brakes.



# Integrated Braking Control (IBC)

*Electronically combines Automatic Retarding Control (ARC) and the Traction Control System (TCS) into one integrated control system.*

## ARC Operating Efficiency Advantages

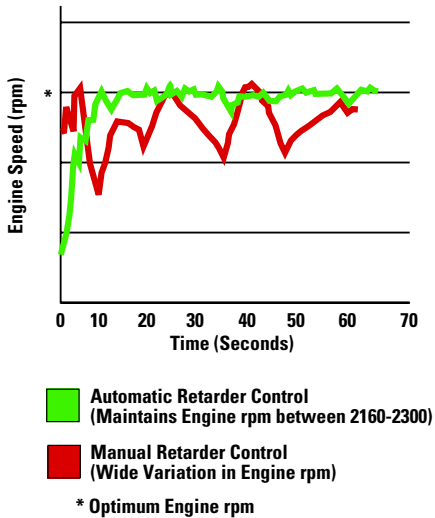

### Automatic Retarder Control (optional).

The ARC electronically controls braking on grade to maintain approximately 2,230 rpm (engine rpm is adjustable from 2,150-2,300 rpm in increments of 10 rpm). ARC is deactivated when the operator applies the brakes or throttle.

**Engine Overspeed Protection.** With the accelerator depressed and/or ARC turned off, ARC will automatically activate at 2,475 rpm to help avoid potentially destructive and often costly engine overspeeds.

### ARC Benefits. Include:

- Increased operating efficiency with faster downhill speeds. By maintaining consistently higher engine speeds, average truck speed will be higher than a manually controlled truck.
- Excellent controllability and reduced operator effort. Automatic brake modulation provides a smoother ride over manual modulation, allowing the operator to focus more on truck operation down the haul road.
- Improved component life, optimized system cooling capability and reduced torque fluctuations result from ARC's precision.
- Faster troubleshooting and diagnosis with self-diagnostic capability and the ability to communicate with ET through the Cat Data Link System.

- Operator awareness through electronic integration and CEMS, alerting the operator to overspeed conditions and critical machine functions.

### Traction Control System (Optional).

Monitors wheel slip so if it exceeds the set limit, the oil-cooled disc brakes are automatically applied to slow the spinning wheel.

**Operator Awareness.** An on-dash indicator shows the operator that TCS is engaged.

**Differential Action.** Utilizes normal differential action to provide superior maneuvering in poor underfoot conditions. Also reduces tire scuffing as compared to positive lock differentials used on other systems.

**Torque.** TCS divides torque equally to reduce stress created on final drives and axles when torque is transferred to one side.

**System Back-up.** Should sensors fail, the normal differential action is still available to maintain control and steering.

# Structures

*The backbone of the Cat off-highway truck.*

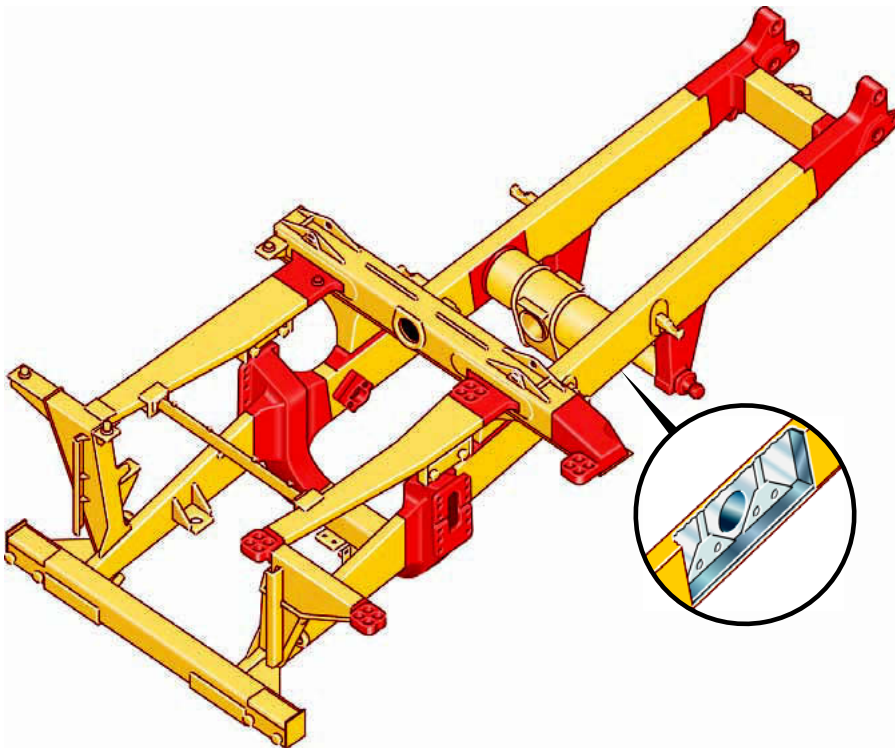

**Box-Section Design.** The 775E frame uses a box-section design, incorporating 20 castings in high stress areas with deep penetrating and continuous wrap-around welding. Mild steel, which provides flexibility, durability and resistance to impact loads even in cold climates is used throughout.

**Castings.** Castings have large radii with internal reinforcing ribs to dissipate stress. Castings move welds to lower stress areas and provide two to three times the strength of equivalent sized fabricated structures.

**Frame Features.** Include:

- Integral front bumper
- Front box beams for suspension cylinder and ROPS support
- Box-section rear crossmember for body and ROPS support with attachment points for maintenance platform and rear engine hood hinge support
- Castings provide additional strength in critical stress areas
- Mild steel plates (290 MPa [42,000 psi] minimum yield strength) and castings (241 MPa [35,000 psi] minimum yield strength) provide flexibility, durability and easy field maintenance.

**Frame Serviceability.** The box-section frame allows simple access to power train components. This open design reduces overall removal and installation time, lowering repair costs. Transmission access is excellent under the raised and pinned body. Repairs can be made without preheating in ambient temperatures above 16° C (60° F) using readily available welding supplies.

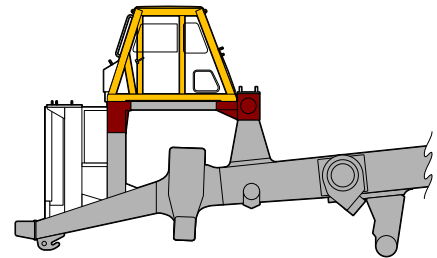

**Rollover Protection Structure (ROPS).**

The ROPS attaches securely to four castings welded into the frame.

**Suspension System.** Designed to dissipate haul road and loading impacts for extended frame life. Four independent, self-contained, oil pneumatic, variable-rebound, suspension cylinders absorb shocks. Rear cylinders allow axle oscillation and absorb bending and twisting stresses. Front cylinders, mounted to the frame, serve as steering kingpins, providing excellent maneuverability and reduced maintenance. Caster and camber are preset.



## Truck Body Options

Caterpillar builds a variety of rugged, durable bodies to perform in the toughest Quarry and Construction applications.



**Design.** 775E bodies are designed to help you obtain the lowest cost-per-ton hauling solution in a variety of material conditions and densities.

**Sidewall and Floor Junctions.** Are joined by five-sided beams to resist impact loading and sustained hauling stresses.

**Box-Section Beams.** Offer increased durability in the floor, sidewalls, top rail, canopy corner and floor areas.

**400 Brinell or HARDOX 400 Steel.** Wear surfaces provide excellent wear resistance and are easily welded without preheating procedures. 400 Brinell steel is used in the dual slope construction body and the flat floor lined body. The flat floor quarry body is made from HARDOX 400 steel.

**Two-Stage Hoist Cylinders.** Provide fast dump cycle times of 9.5 seconds for raise and 12.5 seconds for lower.

**Standard Body.** Comes exhaust heated with options including a full-time muffler or exhaust diverter.

**Custom Attachments.** Including tail extensions, liner packages, sideboards and other custom designs are offered to help ensure rated payload.

**(1) Dual-Slope Construction Body.** Offers the lowest cost-per-ton option in most construction applications.

**Dual-Slope Body Performance.** Efficient under most haul road conditions, but the dual-slope body's strength comes from higher levels of production in sites with rough haul roads and steeper grades.

**Body Floor Construction.** Uses an eight degree "V" bottom for increased load retention, a low center of gravity and reduced shock loading. It also aids in centering the load.

**18 Degree Ducktail and 9 Degree Forward Body Slope.** Retains the load on grades up to 15 percent and higher. This design also helps maintain proper load distribution.

**(2) Flat Floor Quarry Body and Flat Floor Lined Body.** Offers uniform dumping into hoppers, crushers and feeders.

- Flat floor design improves wear characteristics of body tail
- 12 degree forward body floor slope
- Choice of 400 Brinell steel or HARDOX 400 steel

## Operator Station

*Control ease and comfort maximize productivity.*

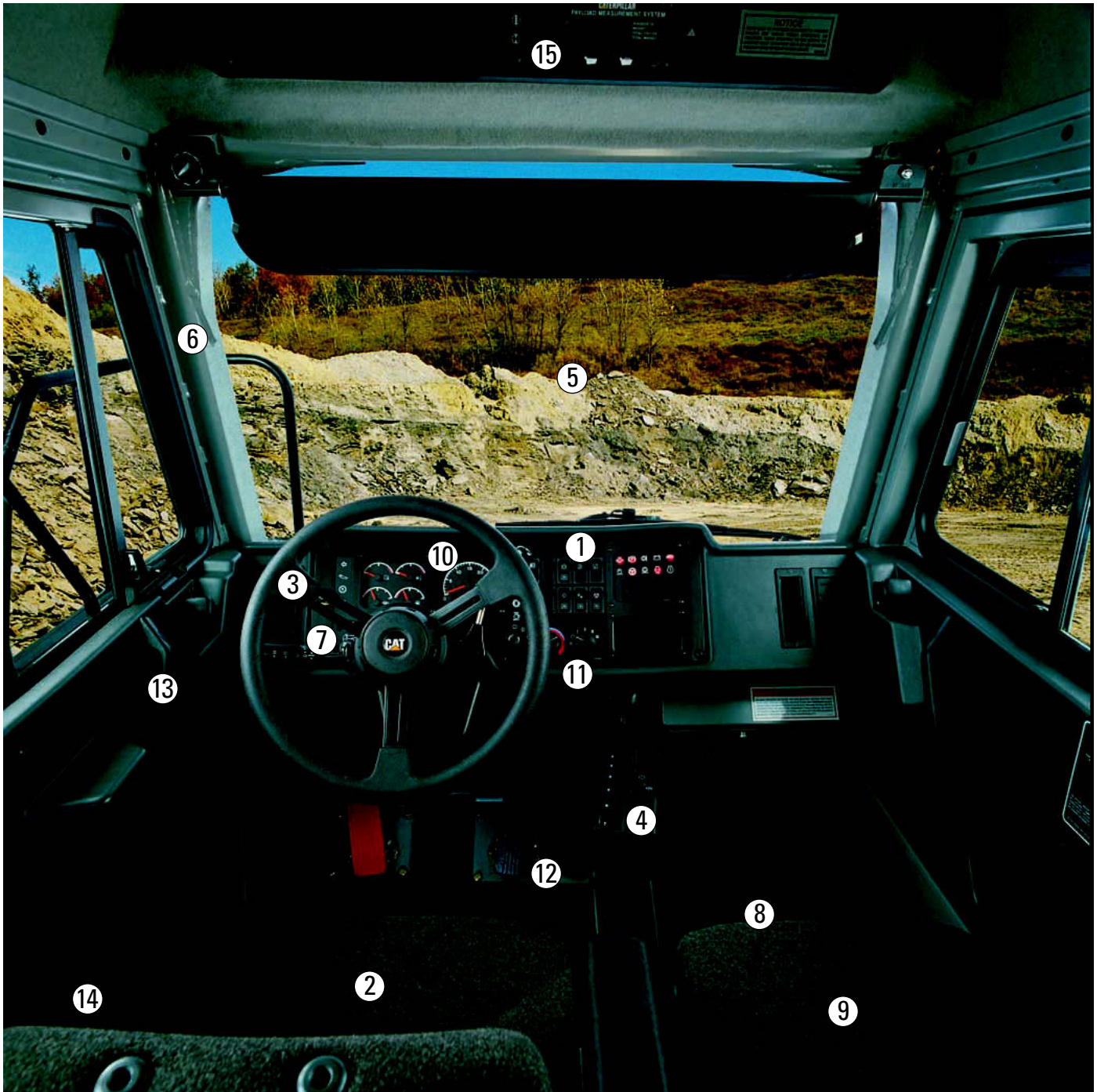



**775E Operator Station.** Rated highly by operators with everything needed for top performance located at the operator's fingertips.

**1) Wraparound Dash Panel.** Offers an easy line-of-sight arrangement, using LED backlit rocker switches.

**2) Caterpillar Contour Series Air Suspension Seat.** Standard and fully adjustable, including an adjustable right-hand armrest.

**3) Tilt-Telescoping Steering Wheel.** With ergonomic grip improves comfort and control. Low effort steering system and ergonomically designed retarder lever reduces operator fatigue. Also includes an enhanced turn signal lever with high beam actuator and electric windshield wiper controls.

**4) Transmission Console.** Has LED backlit gear numbers and ergonomic shift knob.

**5) Visibility.** Exceptional all-around viewing area reduces fatigue and improves productivity.

**6) Integral, Sound-Suppressed ROPS/FOPS Cab.** Is resiliently mounted providing a quiet, protected work environment. The cab is radio-ready with speakers, wiring harness, antenna and mounting bracket.

**7) Front Brake Cut-Out Switch.** Increases front brake component life.

**8) Large Storage Compartment.** 0.10 m<sup>3</sup> (3.5 ft<sup>3</sup>) of storage space is located under the trainer's seat.

**9) Trainer's Seat.** Includes back rest and retractable seat belt.

**10) Caterpillar Electronic Monitoring System (CEMS).** Provides critical data. The system features three separate displays:

- Four-gauge cluster with coolant temperature, oil temperature, brake air pressure, fuel level
- Tachometer, digital speedometer, actual gear indicator
- Message center module

**11) Standard Heater and Optional Air Conditioner.** Includes four-speed fan and nine vents.

**12) Foot Pedals.** Ergonomically designed for increased operator comfort.

**13) Electric Power Window.** For simplified operation.



**14) Electrohydraulic Hoist Lever.** Is fingertip actuated and provides low impact body-down snubbing.



**15) Truck Production Management System (TPMS) (Optional).** Provides payload and cycle time data.

- Cat developed technology utilizes strut pressure sensors and an on-board microprocessor to determine payload weight
- Accurate under normal loading to within  $\pm$  five percent over a normal operating shift
- Delivers consistent accurate payloads and improves efficiency by minimizing overloading and underloading
  - On-board computer stores 1,400 cycles for further analysis of payload weight, cycle segment times, cycle segment distances and actual clock time and date of each cycle
  - External lights signal loading tool operator when payload is reached
  - Internal troubleshooting and fault recording for easier maintenance

## Serviceability/Total Customer Support

*Purchase of a Caterpillar machine includes a total commitment to customer support.*

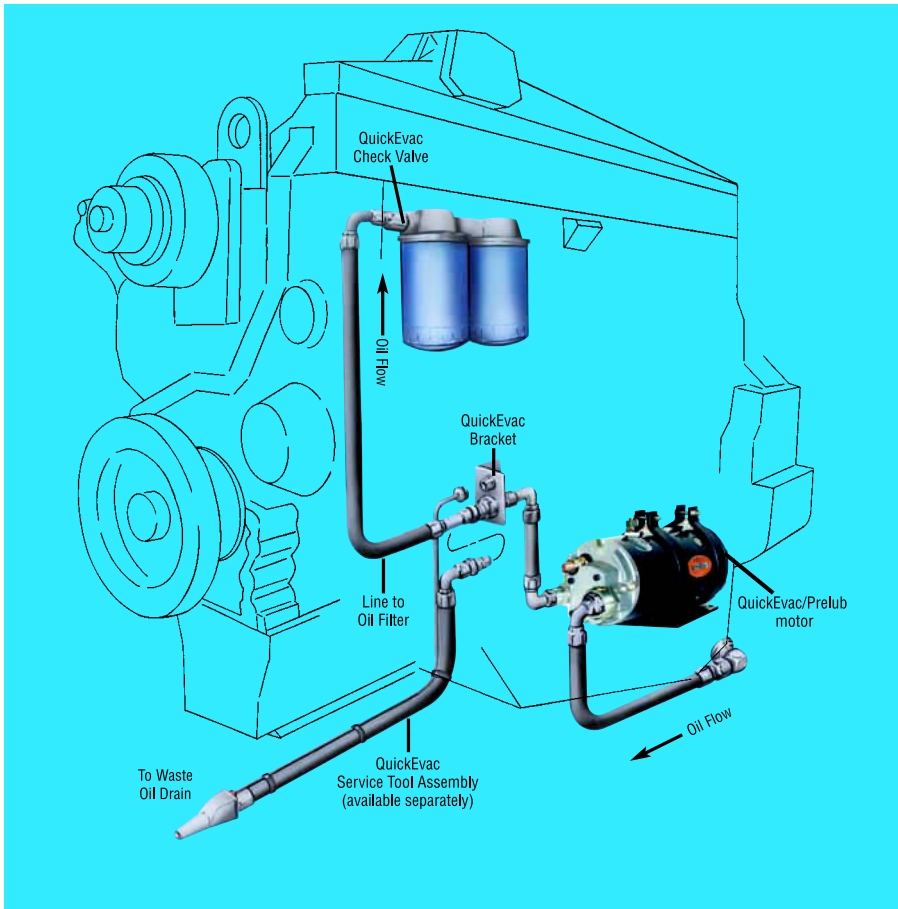

**Cat QuickEvac™ System.** Is an exclusive Caterpillar on-board engine oil evacuation and prelubrication system.

**Automated Engine Oil Change.** A new, state-of-the-art, on-board system evacuates engine sump in less than two minutes and allows for purge of oil filters prior to removal, minimizing oil spills. It delivers new oil through primary filters for filtered protection and ensures new filters are correctly filled following routine oil change.

**Contamination Control.** Environmentally efficient, clean oil changes are ensured since engine sump is evacuated directly into PM trucks or waste containers with flush faced, quick disconnects for fast evacuation and fill. This eliminates handling of waste oil, minimizes chances of oil spillage and enhances Contamination Control efforts by ensuring complete filtration of new oil on engine refill.

### **Complete Engine Prelubrication.**

Provides engine oil pressure prior to engine cranking. Reduces engine dry start wear and risk of cold starts for increased protection of key components. Also provides expanded low temperature range for 15W40 motor oils.

### **Improved Serviceability and Machine Availability.**

Reduces time to complete engine service (changing engine oil, oil filters, fuel filter, air cleaner) by as much as 30 to 50 percent. Improves the ability to schedule engine services at prescribed hours, allows for servicing during normal working hours and integrates easily with PM trucks to further reduce total cycle time of engine service.

### **Machine Platform.**

Provides access to air tanks, brake master cylinder and make-up tank; engine oil level; air filters; steering hydraulic tanks; and battery compartment.



**Ground Level Battery Disconnect Switch.** Facilitates safe, convenient servicing and maintenance.



**On-Board Diagnostics.** With CEMS, provides the machine operator with a three-category warning system and quick access to stored diagnostic data.

**Off-Board Diagnostics.** With ET, allows service technicians access to stored diagnostics data reducing downtime and lowering operating costs. ET stores engine parameter information such as timing, throttle position and fuel flow. Transmission data is available through ET via access to the Cat Data Link System.

**Radial Seal Filters.** Are easy to change, reducing air filter maintenance times.

**Vertical, Spin-On Filters.** Provide for simplified servicing.

**Quick Coupler Pressure Taps.** Located in all hydraulic systems provide clear, quick pressure checks. S-O-S<sup>SM</sup> oil analysis points make oil sampling quick, clean and easy.

**Sealed Electrical Connectors.** Lock out dust and moisture. Color-coded wiring is standard for the entire Cat product line.

**Machine Management Service.** Cat dealers help manage equipment investments with:

- Vehicle systems analysis to help match the right machine to the job
- Preventative maintenance programs
- S-O-S oil analysis and technical analysis programs
- Repair option analysis
- Training for operators and mechanics
- TPMS data analysis

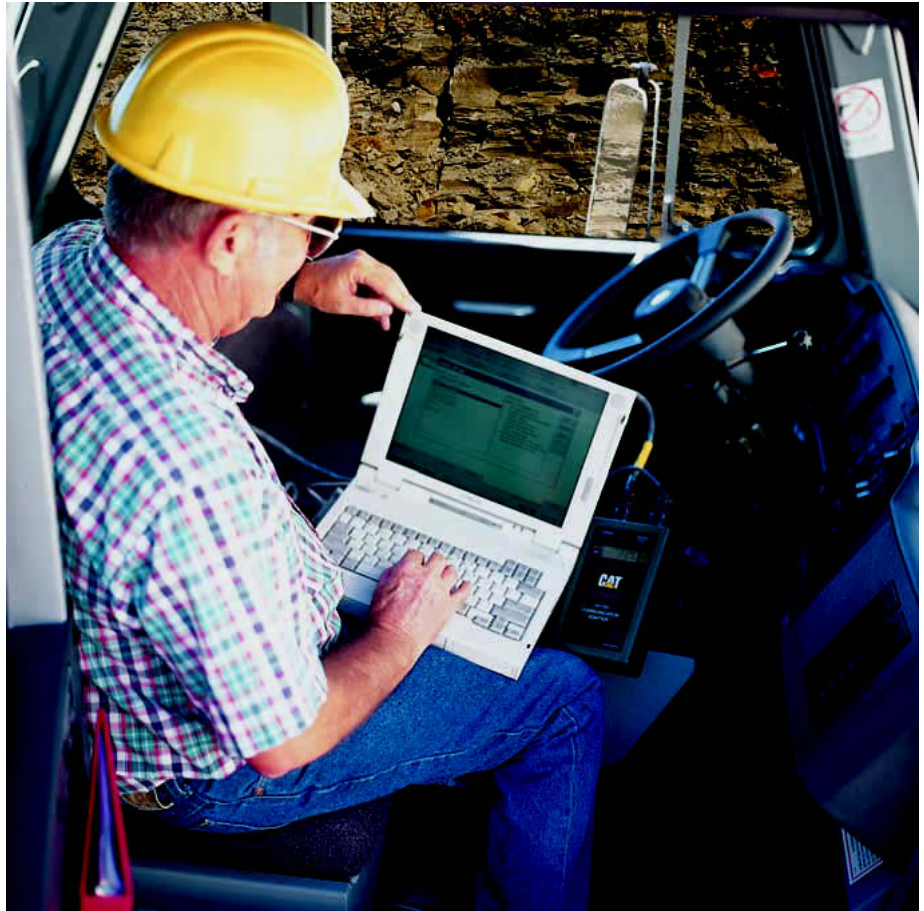

**Parts Availability.** The Caterpillar worldwide computer network locates parts instantly to minimize machine downtime.

**Literature Support.** Caterpillar manuals are easy to use and help provide the full value of an equipment investment.

## Systems/Applications

*The 775E is designed for versatility.*



### **Machine Configuration Options.**

Caterpillar offers a variety of machine configuration options to help meet customer needs.

**Body Options.** Include a full line of standard and custom designs based on specific customer preference, material density, loading tool and site conditions.

**Tire Options.** A full line of standard and custom designs based on specific customer preference, material density, loading tool and site conditions.

**Attachments.** Give the customer options to tailor trucks for specific application requirements, including:

- Truck Production Management System
- Automatic Retarder Control
- Traction Control System
- Custom product offerings
- Muffler/exhaust diverter

**System Approach.** The Caterpillar system approach means increased efficiencies through common design. Haul trucks, loaders, excavators, tractors, engines for generator sets and pumps - all designed by Caterpillar - use common components, parts and design. Commonality reduces customer parts stock, improves parts availability, reduces training/maintenance and improves diagnostics. This system approach adds up to lower cost-per-ton. Dealer support is available to address customer needs regardless of the component.

### **Caterpillar Product Analysis Team**

**(PAT).** Combined with Caterpillar software programs can assist customers with detailed, application evaluation.

**Loader Match.** Designed to work as part of a system, the 775E is best matched to the following Caterpillar loaders:

- 990 Series II - four pass/match
- 992G - three pass/match
- 5130B - three to four pass/match



## Engine

Engine Model	CAT 3412E	
Gross Power	567 kW	760 hp
Flywheel Power	544 kW	730 hp
DIN 70020	756 PS	
Max. Torque	3447 N•m	2,542 lb ft
Torque rise	33%	
Bore	137 mm	5.4 in
Stroke	152 mm	6 in
Displacement	27 L	1,649 in <sup>3</sup>

- Gross power meets ISO 3046-02 standards.
- Flywheel power meets ISO 9249, SAE J1349 JUN95 and EEC80/1269 standards.
- These engine ratings apply at 2,000 rpm when tested under the specified standard conditions for the specified standard.
- Power rating conditions based on standard air conditions of 25° C (77° F) and 99 kPa (29.32 in Hg) dry barometer, using 35° C (95° F) API gravity fuel having an LHV of 42 780 kJ/kg (18,390 Btu/lb) when used at 30° C (86° F) (reference a fuel density of 838.9 g/l [7.001 lb/gal]).
- Net power advertised is the power available at the flywheel when the engine is equipped with fan, air cleaner, muffler and alternator.
- No derating required up to 2300 m (7,500 ft) altitude.

## Transmission

Forward 1	10 kph	6.2 mph
Forward 2	13.9 kph	8.6 mph
Forward 3	18.7 kph	11.6 mph
Forward 4	25.1 kph	15.6 mph
Forward 5	34 kph	21.1 mph
Forward 6	45.9 kph	28.5 mph
Forward 7	65.8 kph	41.1 mph
Reverse	12 kph	7.5 mph

- Maximum travel speeds (standard 24.00-R35)

## Final Drive

Differential ratio	3.64:1
Planetary ratio	4.80:1
Total reduction ratio	17.48:1

- Planetary, full-floating.

## Brakes

Brake surface - front	1395 cm <sup>2</sup>	216 in <sup>2</sup>
Brake surface - rear	61 265 cm <sup>2</sup>	9,496 in <sup>2</sup>

- Meet ISO 3450:1996 standards up to 108 400 kg (239,000 lb) gross operating weight.

## Service Refill Capacities

Fuel Tank	700 L	185 gal
Cooling System	151 L	40 gal
Crankcase	68 L	18 gal
Differentials and final drives	155 L	41 gal
Steering tank	34 L	9 gal
Steering system (includes tank)	60 L	16 gal
Brake/hoist hydraulic tank	133 L	35 gal
Brake/hoist system (includes tank)	307 L	81 gal
Torque converter/transmission sump	53 L	14 gal
Torque converter/transmission system (includes sump)	72 L	19 gal

## Body Hoists

Pump flow - high idle	562 L/min	148 gal/min
Relief valve setting - raise	17 225 kPa	2,750 psi
Relief valve setting - lower	3445 kPa	500 psi
Body raise time @ high idle	9.5 Seconds	
Body lower time float	12.5 Seconds	

- Twin, two-stage hydraulic cylinders mounted inside the main frame, double acting in second stage.
- Power raise in both stages and power down in second stage.

## Suspension

Effective cylinder stroke - front	209 mm	8.2 in
Effective cylinder stroke - rear	149 mm	5.9 in
Rear axle oscillation	±8°	

### Approximate Weights - Quarry Flat Floor

Gross vehicle	108 400 kg	239,000 lb
Chassis	30 400 kg	67,000 lb
Body	13 070 kg	28,810 lb
Front axle - empty	44.3%	
Front axle - loaded	31.2%	
Rear axle - empty	55.7%	
Rear axle - loaded	68.8%	

### Approximate Weights - Flat Floor Lined

Gross vehicle	108 400 kg	239,000 lb
Chassis	30 400 kg	67,000 lb
Body	14 350 kg	31,640 lb
Front axle - empty	44.3%	
Front axle - loaded	31.2%	
Rear axle - empty	55.7%	
Rear axle - loaded	68.8%	

### Approximate Weights - Dual-slope

Gross vehicle	108 400 kg	239,000 lb
Chassis	30 400 kg	67,000 lb
Body	10 800 kg	23,800 lb
Standard Liner	4450 kg	9810 lb
Front axle - empty	45.9%	
Front axle - loaded	31.6%	
Rear axle - empty	54.1%	
Rear axle - loaded	68.4%	

### Capacity - Quarry Flat Floor - 100% fill factor

Struck	31.4 m <sup>3</sup>	41.1 yd <sup>3</sup>
Heaped 3:1	38.3 m <sup>3</sup>	50.1 yd <sup>3</sup>
Heaped 2:1 (SAE)	41.5 m <sup>3</sup>	54.3 yd <sup>3</sup>
Heaped 1:1	50.9 m <sup>3</sup>	66.6 yd <sup>3</sup>

### Capacity - Flat Floor Lined - 100% fill factor

Struck	31.2 m <sup>3</sup>	40.8 yd <sup>3</sup>
Heaped 3:1	37.8 m <sup>3</sup>	49.4 yd <sup>3</sup>
Heaped 2:1 (SAE)	41.2 m <sup>3</sup>	53.9 yd <sup>3</sup>
Heaped 1:1	50.3 m <sup>3</sup>	65.8 yd <sup>3</sup>

### Capacity - Dual-slope - 100% fill factor

Struck	32.7 m <sup>3</sup>	42.8 yd <sup>3</sup>
Heaped 3:1	38.9 m <sup>3</sup>	50.9 yd <sup>3</sup>
Heaped 2:1 (SAE)	41.2 m <sup>3</sup>	53.9 yd <sup>3</sup>
Heaped 1:1	43.5 m <sup>3</sup>	56.9 yd <sup>3</sup>

### Weights

Gross Machine Weight	108 400 kg	239,000 lb
----------------------	------------	------------

### Operating Specifications

SAE (2:1) Capacity	41.5 m <sup>3</sup>	54.3 yd <sup>3</sup>
Nominal Payload Capacity	63.5 tonnes	70 tons

- Refer to the Caterpillar 10/10/20 Payload Policy.

### Tires

- Tires Standard: 24.00-R35 (E4)
- Productive capabilities of the 775E truck are such that, under certain job conditions, TKPH (TMPH) capabilities of standard or optional tires could be exceeded and, therefore, limit production.
- Caterpillar recommends the user evaluate all job conditions and consult the tire manufacturer to make proper tire selection.

---

## ROPS

---

- ROPS Meets SAE J1040 MAY94 and ISO 3471:1994
- ROPS (Rollover Protection Structure) offered by Caterpillar for the machine meets ROPS criteria SAE J1040 MAY94 and ISO 3471:1994.
- When properly installed and maintained, the cab offered by Caterpillar when tested with doors and windows closed as per work cycle procedures specified in ANSI/SAE J1166 MAY90, results in an operator sound exposure  $L_{eq}$  (equivalent sound level) of 79 dB(A).
- This operator A-weighted sound exposure level can be used in conjunction with OSHA, MSHA and EEC Occupational Noise Exposure Criteria.

---

## Sound

---

- Sound Meets SAE J88 APR95
- This machine, in standard configuration, when measured and operated per the prescribed modes has a 15 m sound pressure level of 84 dB(A) for the mode that gives the highest level.

---

## Steering

---

- Steering Meets SAE J1511 FEB94 and ISO 5010:1992
- Turning diameter on front wheel track 21.7 m (72 ft 2 in).
- Machine clearance turning cycle 23.8 m (78 ft 9 in).
- Steering angle (left or right) 31 degrees.
- Separate hydraulic system prevents cross contamination.
- Steering wheel effort is low and cycle times are reduced with variable-displacement, piston-type steering pump.



# Dimensions

All dimensions are approximate.

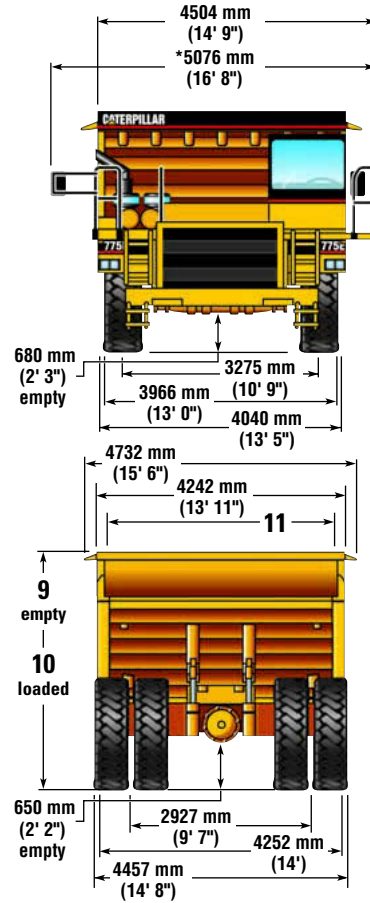
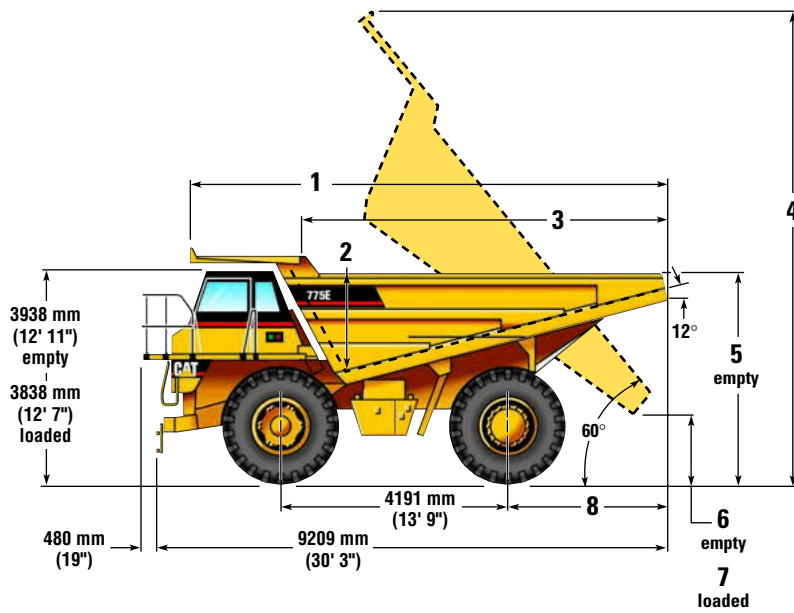

	Quarry Flat Floor		Flat Floor Lined		Dual-slope	
1	8625 mm	28' 4"	8625 mm	28' 4"	8552 mm	28' 1"
2	1904 mm	6' 3"	1896 mm	6' 3"	1967 mm	6' 5"
3	6537 mm	21' 5"	6513 mm	21' 5"	6526 mm	21' 5"
4	8796 mm	28' 11"	8796 mm	28' 11"	8739 mm	28' 8"
5	3912 mm	12' 10"	3912 mm	12' 10"	3927 mm	12' 11"
6	660 mm	2' 2"	660 mm	2' 2"	673 mm	2' 3"
7	550 mm	1' 9"	550 mm	1' 9"	563 mm	1' 10"
8	2872 mm	9' 5"	2872 mm	9' 5"	2779 mm	9' 1"
9	4410 mm	14' 6"	4410 mm	14' 6"	4424 mm	14' 6"
10	4335 mm	14' 2"	4335 mm	14' 2"	4350 mm	14' 3"
11	3990 mm	13' 1"	3974 mm	13' 1"	3988 mm	13' 1"

\* Operating width to r.h. mirror

# Weights

(Approximate)

	Quarry Flat Floor		Flat Floor Lined		Dual-slope	
	kg	lb	kg	lb	kg	lb
Gross vehicle weight	108 400	239,000	108 400	239,000	108 400	239,000
Chassis	30 400	67,000	30 400	67,000	30 400	67,000
Body	13 070	28,810	14 350	31,640	10 800	23,800
Standard liner					4450	9810

Weight Distribution:

	Empty	Loaded	Empty	Loaded	Empty	Loaded
Front axle	44.3%	31.2%	44.3%	31.2%	45.9%	31.6%
Rear axle	55.7%	68.8%	55.7%	68.8%	54.1%	68.4%

# Retarding Performance

The brake performance retarding curves shown in this section are for general guidance only. As each site has many unique environmental and operating conditions that will impact retarding performance, actual site performance could vary considerably from predicted performance. Users should use the retarding speed (gear) recommendations from these tables as a starting point for determining retarding performance and then adjust retarding speeds to their site-specific conditions. In adjusting retarding performance to continuously changing environmental and site-specific conditions, users need to exercise care to maintain brake cooling and machine controllability at all times.

To determine brake retarding performance from retarding tables:

1. Determine the total distance of all downhill grades combined for a given haul profile. This total distance determines the appropriate retarding table (continuous or one of the grade distance tables) applicable to your haul profile.
2. Read from the appropriate gross weight down to percent favorable effective grade. (For these retarding charts, effective grade equals the maximum grade of all downhill haul segments minus rolling resistance – do not use an average grade value.)
3. From the intersection of the gross weight and effective grade line point, read horizontally to the appropriate gear curve. If the horizontal line intersects two gear curves, choose the first gear curve that the horizontal line intersects (reading from right to left) and read the retarding speed performance immediately below this point. If the intersection point falls on a vertical line between two gears, choose the lowest of the two gears to allow for higher engine rpm thus maximizing brake cooling capability.
4. Adjust recommended retarding speeds to site specific (environmental and operational) conditions. If the brake system overheats or specific site conditions dictate (tight turns, short steep grades, manual braking, etc.), reduce ground speed to allow the transmission to shift to the next lower speed range.

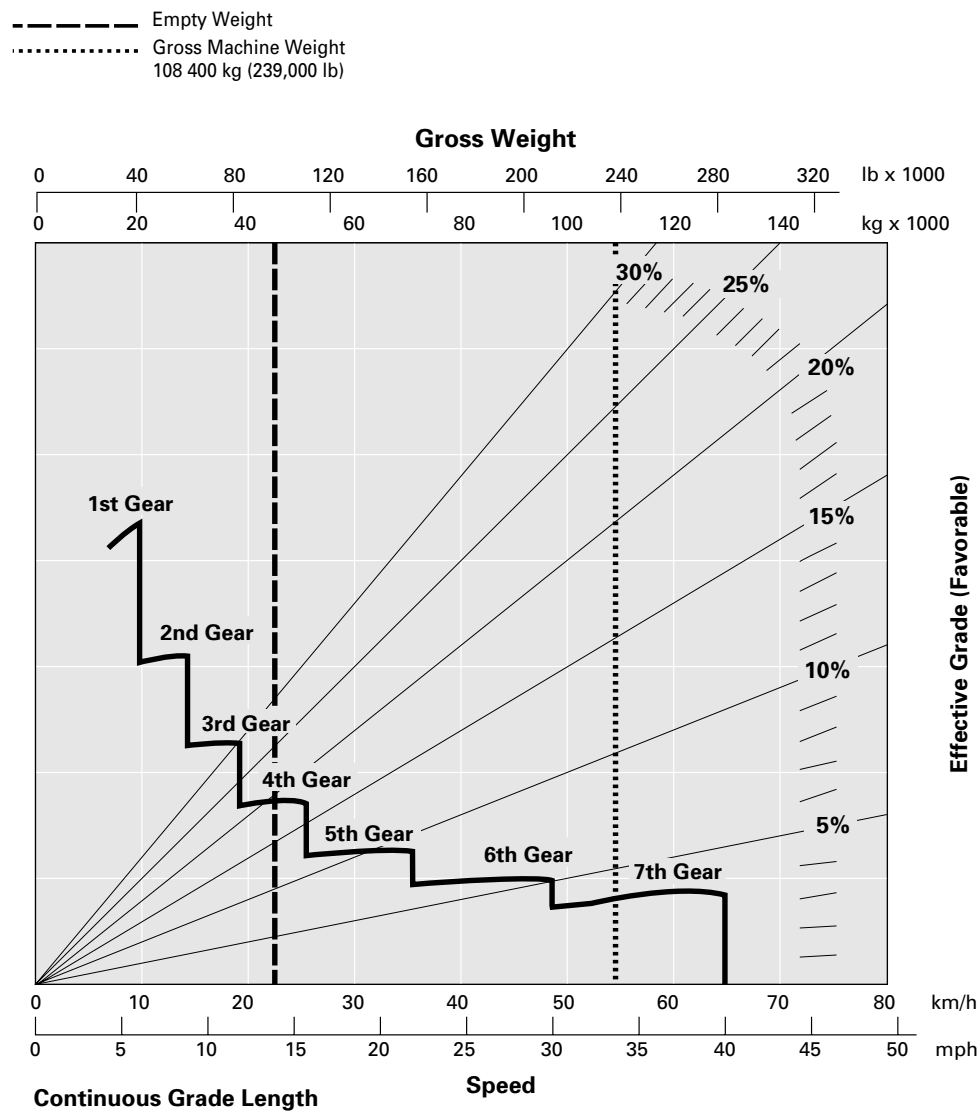

# Retarding Performance (continued)

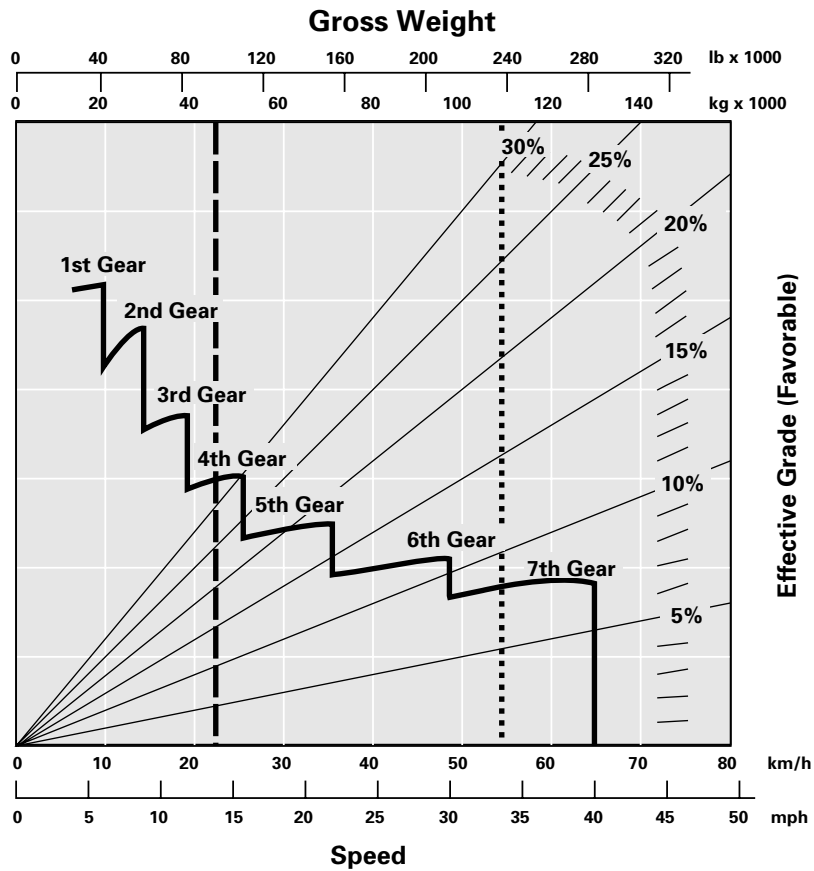

Grade Distance - 450 m (1500 ft)

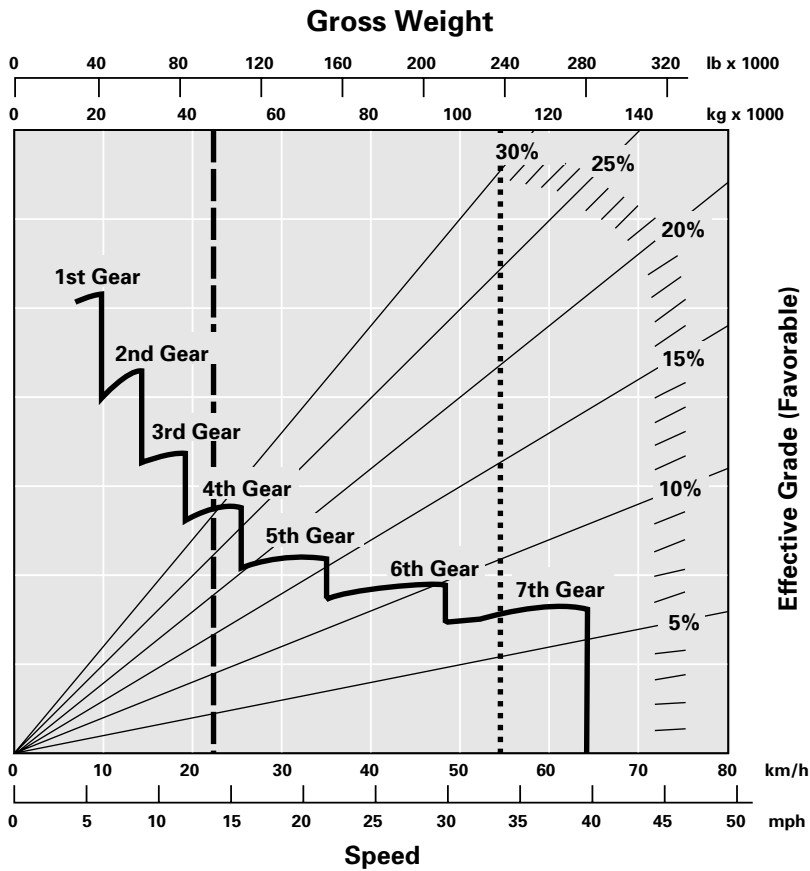

Grade Distance - 600 m (2000 ft)



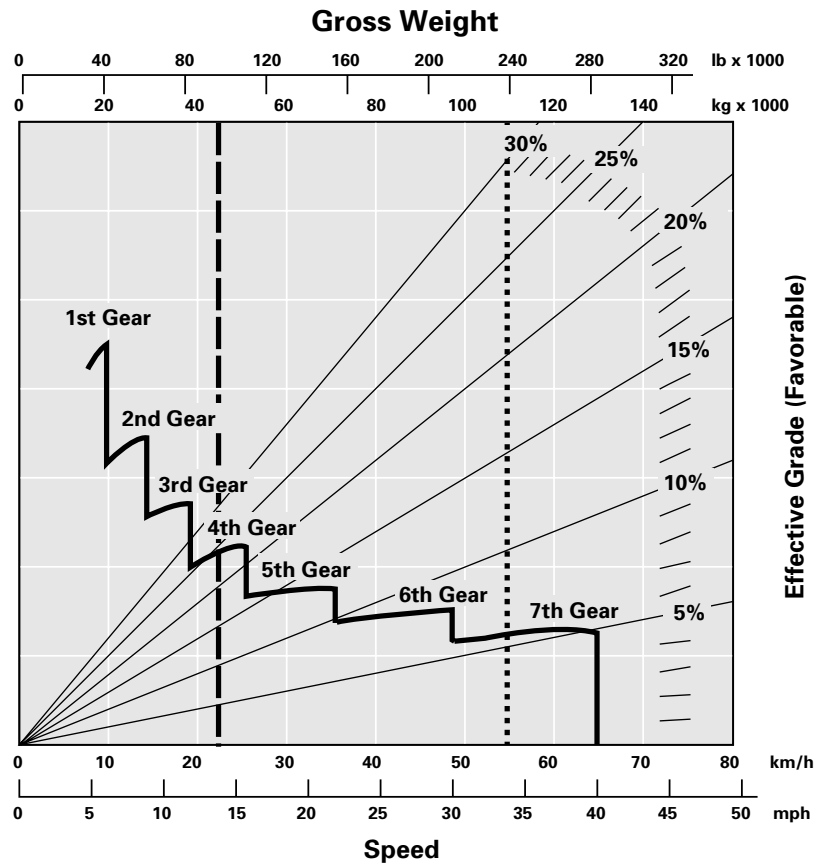
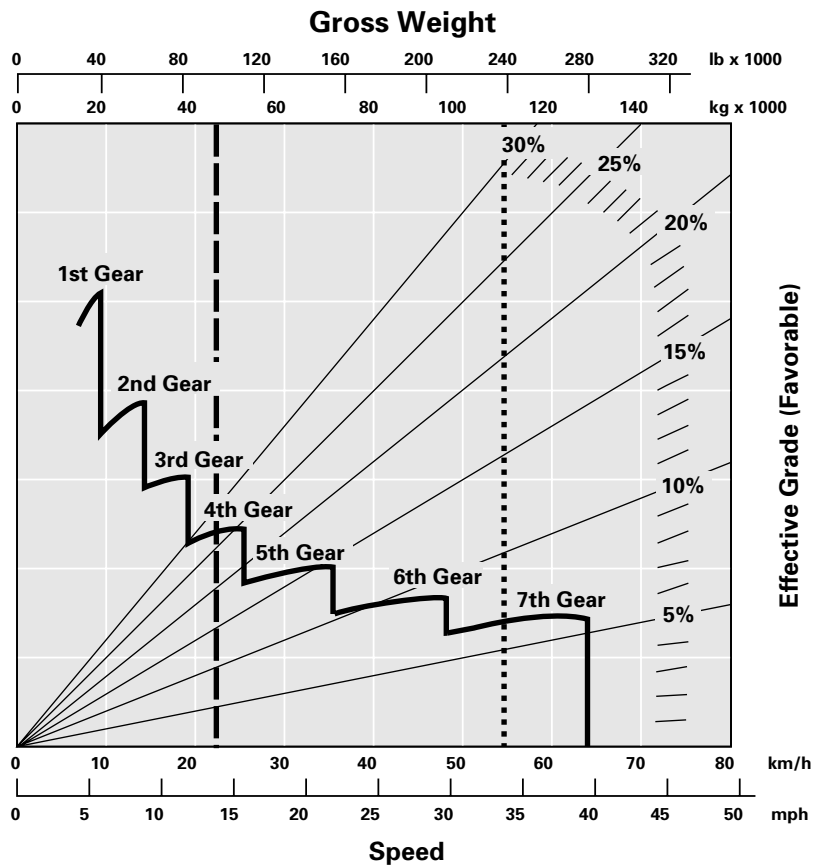

# Gradeability/Speed/Rimpull

To determine gradeability performance, read from gross weight down to the percent of total resistance. Total resistance equals actual percent grade plus one percent for each 10 kg/tonne (20 lb/ton) of rolling resistance. From this weight-resistance point, read horizontally to the curve with the highest obtainable gear, then down to maximum speed. Usable rimpull will depend upon traction available and weight on drive wheels.

- - - - Empty Weight
- · - · - Gross Machine Weight - 108 400 kg (239,000 lb)

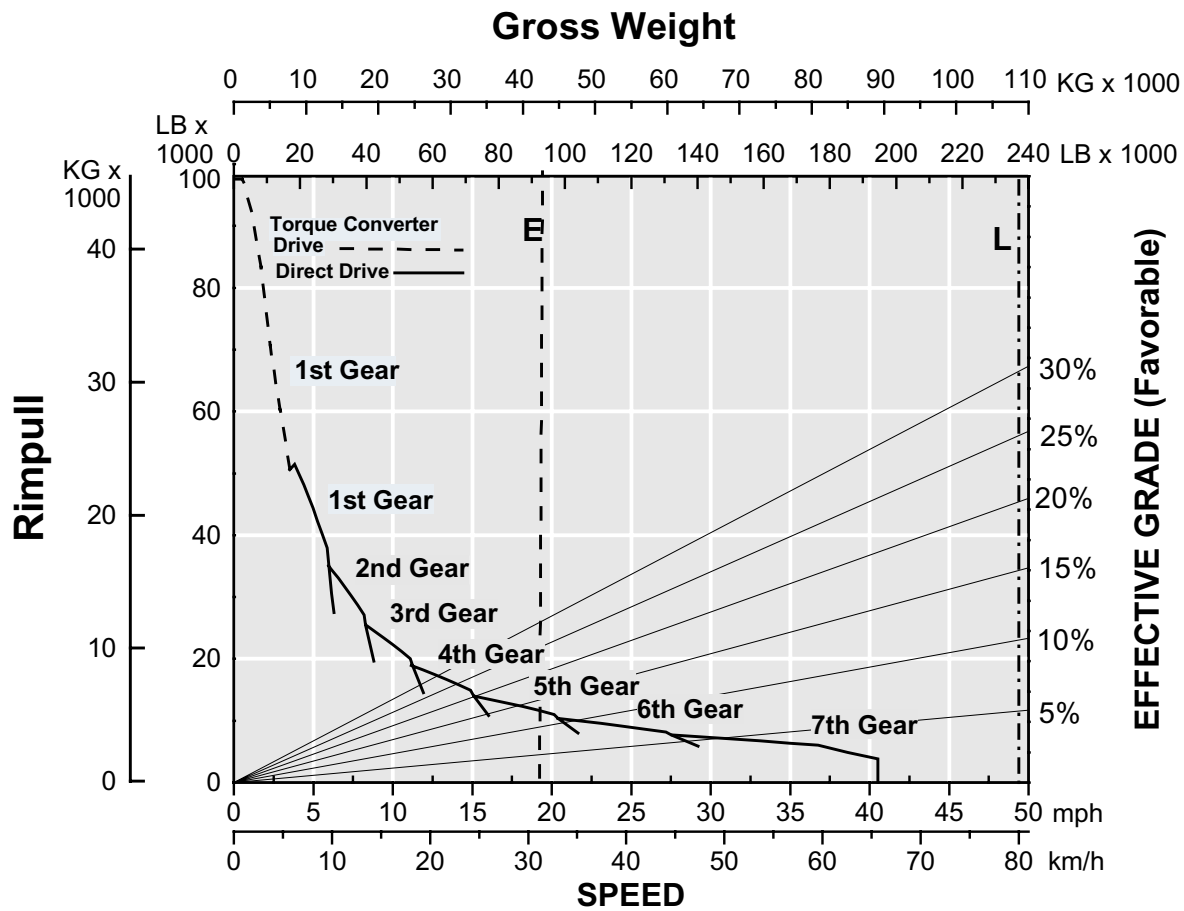

## Standard Equipment

*Standard equipment may vary. Consult a Caterpillar Dealer for specifics.*

Air horn, electric	Heat/defroster 11 070 kCal. (43,930 Btu)
Air line dryer	Hoist lever, finger tip-actuated
Alternator, 50-amp	Lighting system:
Auxiliary jump start receptacle	Back up light
Back up alarm	Dome/courtesy light
Battery disconnect switch, ground level	Hazard and directional signals, LED
Body mounting group	Headlights, Halogen, with dimmer
Brakes:	Stop/tail lights, LED
Caliper disc (front)	Mirrors, right and left
Oil-disc (rear)	Power port, 24-volt
Parking	Precleaner
Secondary	QuickEvac™ System with Prelube
Brake (front) disconnect switch	Reservoirs (separate):
Brake heat exchanger	Brake/hoist
Brake release motor for towing	Steering
Cab, ROPS:	Transmission/torque converter
Caterpillar Contour Series air suspension seat	Retarder
Coat hook	Rock ejectors
Cupholder	Seat belts, retractable
Insulated and sound-suppressed	Seat, passenger
Radio ready	Service platform, bolt-on
Storage compartment	Starting, electric
Sun visor	Steering, automatic supplemental, electric
Tinted glass	Steering wheel, padded, tilt, telescopic
Crankcase guard	Tires, 24.00-35, radial
Diagnostic connection port, 24-volt	Tow hooks, front
Drive line guard	Tow pin, rear
Electrical system, 24-volt	Transmission, electronically controlled automatic power shift with downshift/reverse shift inhibitor, neutralizer during dumping, neutral start switch, engine overspeed protection, directional shift management, programmable top gear, body-up shift limiter, economy shift mode and control throttle shifting
Electronic Monitoring System	Vandalism protection locks
Filters, spin-on	Window, electronic power (operator)
Gauges:	Windshield wipers and washer, electric intermittent
Actual Gear Indicator	
Air pressure	
Brake oil temperature	
Coolant temperature	
Fuel gauge	
Hour meter, electric	
Odometer	
Speedometer	
Tachometer	



## Optional Equipment

With approximate changes in operating weights.

Optional equipment may vary. Consult a Caterpillar Dealer for specifics.

	kg	lb		kg	lb
Air conditioning	90	198	Integrated brake control	56	123
Automatic lube system	60	135	Muffler	116	256
Automatic Retarder Control (ARC)	6	13	Spare rim 432 mm (17")	390	860
Clustered grease fittings	20	50	Traction Control System (TCS)	50	110
Engine coolant heater - 120-volt	3	7	Truck Production Management System (TPMS)	46	100
Engine coolant heater - 240-volt	4	9	Wheel chocks	25	50
Ether starting aid	5	10	Wiggins fast fuel change	2	5
Exhaust diverter/muffler	93	205	Wiggins high-speed oil change	1	2
Fuel heater kit	5	12			

## Weight/Payload Calculation\*

(Example)

	Quarry Flat Floor		Dual Slope		Flat Floor Lined	
	kg	lb	kg	lb	kg	lb
Empty Chassis Weight	30 400	67,000	30 400	67,000	30 400	67,000
Fuel Correction (90% × 185 gal × 7.1 lbs/gal)	530	1,170	530	1,170	530	1,170
Optional Attachments Weight						
Debris Allowance (4% of chassis)	+1210	+2680	+1210	+2680	+1210	+2680
Chassis Weight	32 140	70,850	32 140	70,850	32 140	70,850
Body Weight	13 070	28,810	10 880	23,800	14 350	31,640
Body Attachments Weight	+0	+0	+4450	+9810	+0	+0
Total Empty Operating Weight	45 210	99,660	47 470	104,460	46 490	102,490
<b>Target Payload</b>	<b>+63 190</b>	<b>+139,340</b>	<b>+60 930</b>	<b>+134,540</b>	<b>+61 910</b>	<b>+136,510</b>
Gross Machine Operating Weight	108 400	239,000	108 400	239,000	108 400	239,000

\*Note: Refer to Caterpillar's 10/10/20 Payload Policy for Quarry and Construction Trucks.

---

# Notes

# 775E Off-Highway Truck

For more complete information on Cat products, dealer services, and industry solutions, visit us on the web at [www.CAT.com](http://www.CAT.com)

© 2001 Caterpillar  
Printed in U.S.A.

AEHQ5457 (11-01)

Replaces AEHQ5139-02

Materials and specifications are subject to change without notice.  
Featured machines in photos may include additional equipment.  
See your Caterpillar dealer for available options.

**CATERPILLAR**<sup>®</sup>