

# QJ241 JAW CRUSHER ENGINEERING IN MOTION

## TECHNICAL SPECIFICATIONS

KEY SPECIFICATIONS	DATA
Crusher	
Type	Single Toggle - C10
Feed opening	1000 mm x 650 mm / 40" x 26"
Speed	320 rpm
Adjustment type	Hydraulic Wedge
Drive	Hydraulic via V Belts
CSS range	50 - 150 mm / 2" - 6"

KEY SPECIFICATIONS	DATA
Power pack	
Engine	Stage 3A / Tier 3 CAT C7.1 Acert Stage 3B / Tier 4i CAT C7.1 Acert Stage 4 / Tier 4 Final CAT C7.1
Engine power	168 kW / 225 hp
Diesel tank capacity	660 litres / 174 USG
Hydraulic tank capacity	660 litres / 174 USG

Note. All weights and dimensions are for standard units only

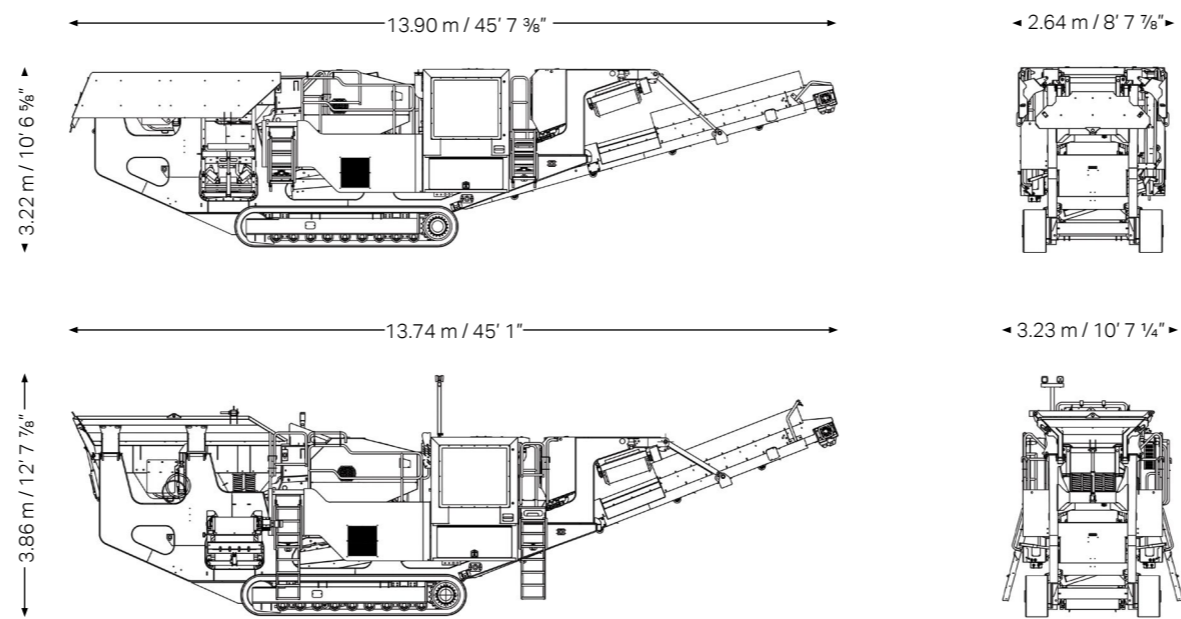

Standard transport weight 32,568 kg / 71,800 lbs

1 Heavy duty shaft and bearings with automatic greasing system as standard

2 Level sensor to optimize feed rate into the crusher (optional)

3 Heavy duty torque arm and bent axis motor providing a robust drive and easy belt adjustment

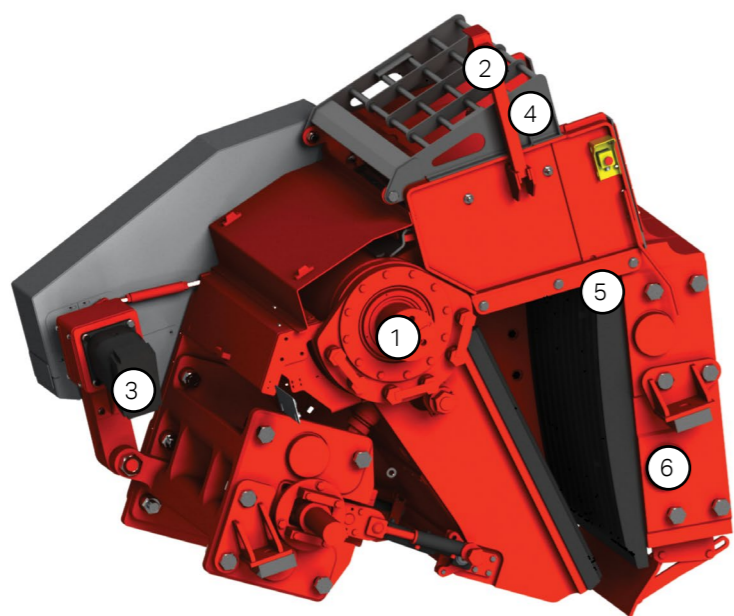

4 Jaw guard to withstand heavy forces of ejected material from the jaw

5 Mn corrugated jaw plates

6 Bolted mainframe for maximum strength and durability.



# QJ241 JAW CRUSHER ENGINEERING IN MOTION

KEY SPECIFICATIONS	DATA
Equipment	Single toggle C10 jaw crusher
Feed opening	1000 mm x 650 mm / 40" x 26"
Optimum feed size	520 mm <sup>3</sup> / 21 inch <sup>3</sup>
Engine	C7.1 Acert 168 kW / 225 hp
Transport dimensions	13.90 m / 45' 7 3/8" (l) 2.64 m / 8' 7 7/8" (w) 3.22 m / 10' 6 5/8" (h)
Weight	32,568 kg / 71,800 lbs

## HIGH MOBILITY

The QJ241 is the most compact unit in the world leading series of jaw crushers from Sandvik. Specifically designed for the smaller operation, it can achieve impressive rates of production with excellent reduction ratios.

The machine is equipped with an extended main conveyor which can be hydraulically raised or lowered, making it the ideal solution for rebar clearance in recycling applications.

Although purpose developed for the contractor and recycling markets the crusher is equally productive and suitable for quarry operators seeking easy manoeuvrability and high quality.

## FEATURES INCLUDE:

- Emissions compliant 168 kW / 225 hp engine for powerful cost efficient performance
- Automatic central lubrication system to reduce maintenance time
- 50°C ambient temperature capability without the need for a change of oil
- Reverse crushing action to relieve blockages, crush sticky problematic materials and asphalt
- Jaw level sensor available for optimum regulation of material flow into the crusher
- Designed for optimum fuel economy and low operating costs.

- 2 Feeder**
- Large capacity vibrating variable speed stepped grizzly feeder
  - Improved load control system for the feeder drive to ensure continuous, uninterrupted crushing
  - Wear resistant liner plates (optional)

- 1 Hopper**
- Reinforced hopper with hydraulically folding doors for quick setup
  - Wear resistant liner plates (optional)

- 3 Jaw**
- High performing 1000 x 650 mm / 40" x 26" jaw
  - Hydraulically adjustable CSS for a variety of applications
  - Reversible crushing action to relieve blockages and for crushing asphalt
  - Level sensor fitted to jaw to optimize feed rate into the crusher (optional)

- 4 Power pack**
- 168 kW / 225 hp emissions compliant engine
  - Easy access to engine compartment for service and maintenance
  - Ground level drainage points
  - Large capacity 660 litres / 174 USG diesel tank

- 5 Cooling fan**
- Hydraulically driven cooling fan with auto reverse to back flush dust from radiator (3B only)

- 6 Main conveyor**
- 800 mm / 31 1/2" wide conveyor with a discharge height of 3444 mm / 11' 3 5/8"
  - Hydraulic raise / lower facility to give increased clearance for rebar discharge in recycling applications
  - Tunnel arrangement to reduce catchment points in recycled materials
  - Speed wheel fitted to the main conveyor to stop the feeder
  - Dust suppression spray bars fitted as standard
  - Overband magnet removes rebar for recycling and demolition applications (optional)
  - Canvas covers (optional)

- 7 Chassis**
- Heavy duty fabricated chassis on a tracked frame

- 8 Control system**
- Highly efficient hydraulic and electrical system provides ultimate system control
  - User friendly PLC control system with colour screen for full automated control

- 9 Tracks**
- 400 mm / 15 1/2" wide tracks driven by proportional umbilical control
  - Radio remote (optional)

- 10 Steel pipework (other side of machine)**
- Provides a safe and maintenance-free sealing solution, combined with better heat dissipation

- 11 Natural fines conveyor (optional)**
- Belt width 650 mm / 25 1/2"



## STANDARD FEATURES



Hydraulic raise and lower facility



User friendly PLC control system with colour screen



Steel pipework for better heat dissipation



Easy access to engine compartment



Tunnel arrangement



Extended main conveyor for massive stockpiling